

***CERTIFIED
TEST REPORT***

**Cooper Power Systems
DEADFRONT ARRESTERS**

Cooper Power Systems
DEADFRONT ARRESTERS

CERTIFICATION

*Statements made and data shown are, to the best of our knowledge and belief,
correct and within the usual limits of commercial testing practice.*



John P. DuPont
Chief Product Engineer



Brian T. Steinbrecher
Director of Engineering,
Line Installation & Protective Equipment

INTRODUCTION

The Deadfront M.O.V.E. and Parking Stand Arrester are used to optimize the surge protection of deadfront URD systems.

The arresters are designed to operate easily with a hotstick. The designs are compact and provide a clean profile within the smallest padmounted cabinets.

This test report certifies that the arresters were designed and then successfully tested to IEEE Standard C62.11-2005, "Metal-Oxide Surge Arresters for Alternating Current Power Circuits" and appropriate portions of IEEE 386-2006, "Separable Insulated Connectors for Power Distribution Systems Above 600 Volts".

The 15kV and 25kV Class Deadfront M.O.V.E. Arrester and VariGAP M.O.V.E. Arrester are offered with the interface that mates to the 200 Amp loadbreak bushing that meets the dimensional requirements of IEEE 386-2006 for separable connectors. The duty-cycle ratings offered are 3kV to 21kV (9kV to 21kV VariGAP).

The 15kV and 25kV Class Deadfront Parking Stand M.O.V.E Arrester and VariGAP M.O.V.E. Arrester is offered with the 200 Amp loadbreak bushing interface that meets the dimensional requirements of IEEE 386-2006 for the separable connectors. The duty-cycle ratings offered are 3kV to 21kV (9kV to 21kV VariGAP).

The 35kV Class M.O.V.E Arrester and VariGAP M.O.V.E. Arrester meet the dimensional requirements of IEEE 386-2006 figure 8, No. 1A. The duty-cycle ratings offered are 10kV to 30kV (10kV to 27kV VariGAP).

The 25kV Class Deadfront POSI-BREAK M.O.V.E Arrester and VariGAP POSI-BREAK M.O.V.E. Arrester are offered with the interface that mates to the 200 Amp loadbreak bushing that meets the dimensional requirements of IEEE 386-2006 for separable connectors. The duty cycle ratings offered are 3kV to 21kV (9kV to 15kV VariGAP).

TEST PROGRAM

Objective:

To demonstrate that the M.O.V.E. Deadfront Arrester and VariGAP M.O.V.E. Deadfront Arrester meet all performance requirements.

To demonstrate that the Deadfront POSI-BREAK M.O.V.E. Arrester and Deadfront POSI-BREAK VariGAP M.O.V.E. Arrester meets all performance requirements please refer to the verification test program on page 5 of this document.

Procedure:

The following design tests were performed on a sufficient number of samples to demonstrate that the M.O.V.E. Deadfront Arrester and VariGAP M.O.V.E. Deadfront Arrester meet all performance requirements.

Design Tests:

- A. Discharge Voltage Current Characteristics Per IEEE C62.11-2005, Para. 8.3.2.1
- B. Discharge Voltage Time Characteristics Per IEEE C62.11-2005, Para. 8.3.2.2
- C. Front-of-Wave Impulse Protective Level..... Per IEEE C62.11-2005, Para. 8.4.2.1
- D. 1.2/50 Impulse Protective Level Per IEEE C62.11-2005, Par. 8.4.2.2
- E. Power Frequency Sparkover Per IEEE C62.11-2005, Par. 8.2
- F. Accelerated Aging Procedure Per IEEE C62.11-2005, Par. 8.5
- G. Duty Cycle Per IEEE C62.11-2005, Par. 8.14
- H. Low-Current, Long-Duration Per IEEE C62.11-2005, Par. 8.13
- I. High-Current, Short-Duration..... Per IEEE C62.11-2005, Par. 8.12
- J. Temporary Overvoltage Per IEEE C62.11-2005, Par. 8.15
- K. Deadfront Arrester Failure Mode Per IEEE C62.11-2005, Par. 8.20
- L. Corona Testing of Housing Per IEEE 386-2006, Par. 7.4
- M. Impulse Testing of Housing Per IEEE 386-2006, Par. 7.5.3
- N. A.C. Hipot Testing of Housing Per IEEE 386-2006, Par. 7.5.1
- O. D.C. Hipot Testing of Housing Per IEEE 386-2006, Par. 7.5.2

Results:

The M.O.V.E. Deadfront Arrester and VariGAP M.O.V.E. Deadfront Arrester meet all performance requirements.

TEST PROGRAM –

Deadfront POSI-BREAK M.O.V.E Arrester and Deadfront POSI-BREAK M.O.V.E VariGAP Arrester

The design of the arrester portion of the Deadfront M.O.V.E. Arrester has not been modified in any way, and the functionality of this product has not been altered. All expected electrical performance and surge protection provided by a specifically rated Deadfront M.O.V.E Arrester is maintained when substituting to the POSI-BREAK design interface.

The only design change implemented in the Deadfront POSI-BREAK M.O.V.E. Arrester is in the mating interface of the rubber elbow housing. In addition, the current POSI-BREAK probe is used in place of the present Deadfront M.O.V.E. probe.

In order to demonstrate that the design of the Deadfront POSI-BREAK M.O.V.E. Arrester meets the performance requirements to prevent partial vacuum induced switching flashovers and normal operating requirements, a sufficient number of samples shall pass the requirements of the tests listed below:

- P. Operating Force Test..... Per IEEE 386-2006, Par. 7.14
- Q. Operating Interface AC Withstand Test.....Per IEEE 386-2006, Annex B , Option B
- R. Corona testing of Housing Per IEEE 386-2006, Par. 7.4
- S. Impulse testing of Housing Per IEEE 386-2006, Par. 7.5.3
- T. A.C. Hipot Testing of Housing Per IEEE 386-2006, Par. 7.5.1
- U. D.C. Hipot Testing of Housing Per IEEE 386-2006, Par. 7.5.2

Results:

The POSI-BREAK M.O.V.E. Deadfront Arrester and POSI-BREAK VariGAP M.O.V.E. Deadfront Arrester meet all performance requirements.

TEST A
DISCHARGE VOLTAGE CURRENT CHARACTERISTICS

Objective:

To determine the maximum discharge voltage characteristics of the arrester at 0.5, 1.5, 3.0, 5.0, 10.0 and 20kA crest in accordance with IEEE C62.11-2005, Paragraph 8.3.2.1.

Procedures:

- Sample arresters were connected directly to ground without using the normal 3 foot ground leads.
- The samples were impulsed using an 8x20 μ s wave shape at 0.5, 1.5, 3.0, 5.0, 10.0 and 20kA crest.
- The discharge voltage crest was measured.

Results:

Chart #1 shows the maximum discharge voltages for Deadfront M.O.V.E. arresters. Chart #3 shows the maximum discharge voltages for VariGAP M.O.V.E. arresters.

TEST B
DISCHARGE VOLTAGE TIME CHARACTERISTICS

Objective:

To obtain the front-of-wave protective level of the arrester based on 5kA crest impulse that results in a discharge voltage cresting in 0.5 μ s in accordance with IEEE C62.11-2005, Paragraph 8.3.2.2.

Procedures:

- Sample arresters were connected directly to ground without using the normal 3 foot ground leads.
- A classifying current of 5kA crest was used to determine the protective level.
- The arresters were impulsed using front times of 8 μ s, 2 μ and 1 μ s.
- The maximum discharge voltage and the time to voltage crest were measured.
- The voltage/time measurements were plotted on linear voltage versus log time paper and the maximum voltage at 0.5 μ s was determined.

Results:

Chart #1 shows the front-of-wave protective levels for Deadfront M.O.V.E. arresters. Chart #3 shows the front-of-wave protective levels for VariGAP M.O.V.E. arresters.

TEST C
IMPULSE PROTECTIVE LEVEL VOLTAGE – TIME CHARACTERISTICS
For VariGAP M.O.V.E. Arresters

Objective:

To determine if the VariGAP M.O.V.E. arrester's protective level is a function of the arrester's maximum sparkover value or its corresponding discharge voltage for a specified wave shape in accordance with IEEE C62.11-2005, Paragraph 8.4.2.1.

Procedures:

- Sample arresters were connected directly to ground without using the normal 3 foot ground leads.
- The arresters were impulsed with 5 positive and 5 negative polarity impulses.
- The impulses had a prospective magnitude of 1.2 times the arresters 0.5 μ s crest, 5kA discharge voltage. The nominal rate of rise of the test wave fronts were (100/12) kV/ μ s for each kV of arrester rating.
- The maximum arrester voltage was measured.
- The arresters 0.5 μ s crest, 5kA discharge voltage was compared to the maximum front-of-wave impulse sparkover.

Results:

The 0.5 μ s crest discharge voltage was found to be greater than the front-of-wave impulse sparkover. Chart #3 lists both values.

TEST D
1.2/50 IMPULSE PROTECTIVE LEVEL
For VariGAP M.O.V.E. Arresters

Objective:

To determine if the VariGAP M.O.V.E. arrester impulse sparkover voltage will exceed the 8/20 μ s discharge voltage at 5kA in accordance with IEEE C62.11-2005, Paragraph 8.4.2.2.

Procedures:

- Sample arresters were connected directly to ground without using the normal 3 foot ground leads.
- A prospective wave with a minimum crest of 1.2 times the arrester's discharge voltage at 5kA, with an 8/20 μ s wave, and with a wave shape of 1.2/50 μ s was used.
- The arresters were impulsed with 5 positive and 5 negative polarity impulses.
- The maximum arrester voltage was measured.
- The 8/20 μ s, 5kA discharge voltage was compared to the maximum 1.2/50 impulse sparkover.

Results:

The 8/20 μ s discharge voltage at 5kA was greater than the 1.2/50 impulse sparkover, so no further testing was required. Chart #5 lists the 1.2/50 impulse sparkover values.

TEST E
POWER FREQUENCY SPARKOVER
of the VariGAP M.O.V.E. Arrester

Objective:

To determine the minimum power frequency sparkover voltage in accordance with IEEE C62.11-2005, Paragraph 8.2.

Procedures:

- The VariGAP M.O.V.E. arresters were energized with an increasing 60 Hz voltage until sparkover occurred.
- The last peak voltage value, prior to sparkover, was converted to the RMS equivalent by dividing by the square root of 2.

Results:

Chart #3 shows the performance results.

TEST F
ACCELERATED AGING PROCEDURE

Objective:

To verify the K_C and K_R ratios of the Cooper Power Systems Deadfront Arrester in accordance with IEEE C62.11-2005, Paragraph 8.5.

$$K_C = \text{MCOV Ratio}$$
$$K_R = \text{Duty Cycle Ratio}$$

These ratios were determined to calculate the test values of MCOV and duty cycle voltages used during testing.

Procedures:

- Samples were placed in an oven at 115°C and energized at MCOV for 2,000 hours.
- The watts loss was measured at 5 hours at the MCOV and duty cycle voltage levels.
- The watts loss was remeasured at 2,000 hours at MCOV and duty cycle voltage levels.

- $K_C = \frac{\text{Watts Loss @ 2,000 Hrs @ MCOV}}{\text{Watts Loss @ 5 Hrs @ MCOV}}$

- $K_R = \frac{\text{Watts Loss @ 2,000 Hrs @ DC Voltage}}{\text{Watts Loss @ 5 Hrs @ DC Voltage}}$

- If K_C and $K_R \leq 1$, then K_C and K_R are equal to 1.

Results:

- K_C and $K_R = 1$.

TEST G **DUTY CYCLE**

Objective:

To demonstrate that the Cooper Power Systems Deadfront Arresters meet the duty cycle requirements in accordance with IEEE C62.11-2005, Paragraph 8.14.

Procedures:

- Each VariGAP M.O.V.E. Arrester sample was measured for power-frequency sparkover.
- Each sample was impulsed with a 5kA crest, 8x20 μ s wave and the discharge voltage measured.
- Each sample was energized at K_R times the duty cycle voltage ($K_R = 1$), for the duration of time needed to allow 20 impulses.
- Each sample was impulsed with a 5kA crest surge of 8x20 μ s wave shape.
- The impulse occurred at approximately 60° before the crest on the power frequency wave.
- Each sample was impulsed once every 50 to 60 seconds for 20 consecutive impulses.
- After the 20th impulse, the sample was de-energized and placed into an oven until it stabilized at 85°C.
- Each sample was removed from the oven and immediately energized at K_R times the duty cycle voltage, $K_R = 1$ and impulsed twice more.
- Immediately after, the samples were energized at K_C times MCOV, ($K_C = 1$), for 30 minutes minimum to show that there was no thermal recovery problem.
- Each sample was impulsed with a 5kA crest 8x20 μ s wave and the discharge voltage measured. The discharge voltage was compared to the discharge voltage taken prior to duty cycle to make sure that it did not vary by more than $\pm 10\%$.
- Each VariGAP M.O.V.E. Arrester sample was measured for power-frequency sparkover. The sparkover value was compared to the sparkover measured prior to duty cycle to make sure that it did not change by more than $\pm 10\%$.
- The samples were inspected after testing to assure that no physical damage occurred.

Results:

The Cooper Power Systems Deadfront Arresters met the duty cycle test requirements of 22 impulses, thermal recovery, <10% change in discharge voltage, and no physical damage.

TEST H
LOW-CURRENT, LONG-DURATION

Objective:

To demonstrate that the Cooper Power Systems Deadfront Arresters meet the low-current, long-duration requirements in accordance with IEEE C62.11-2005, Paragraph 8.13.

Procedures:

- Each VariGAP M.O.V.E. Arrester sample was measured for power-frequency sparkover.
- Each sample was impulsed with a 5kA crest, 8x20 μ s wave and the discharge voltage measured.
- Each sample was impulsed six times, once every 50 to 60 seconds. The sample was allowed to cool to room temperature. This procedure was repeated two more times.
- Immediately after the 18th shot, the sample was placed into an oven until it stabilized at 85°C.
- The sample was removed from the oven and impulsed two more times.
- Immediately after the 20th shot, the sample was energized at K_C times MCOV ($K_C = 1$) for 30 minutes minimum to show that there was no thermal recovery problem.
- Each sample was impulsed with a 5kA crest 8x20 μ s wave and the discharge voltage measured. The discharge voltage was compared to the discharge voltage taken prior to the low-current, long-duration testing to make sure that it did not vary by more than $\pm 10\%$.
- Each VariGAP M.O.V.E. Arrester sample was measured for power-frequency sparkover. The sparkover value was compared to the sparkover measured prior to low-current, long-duration to make sure that it did not change by more than $\pm 10\%$.
- The samples were inspected after testing to assure that no physical damage occurred.

Results:

The Cooper Power Systems Deadfront Arresters met the low-current, long-duration requirements of 20 impulses, thermal recovery, <10% change in discharge voltage, and no physical damage.

TEST I
HIGH-CURRENT, SHORT-DURATION

Objective:

To demonstrate that the Cooper Power Systems Deadfront Arresters meet the high-current, short-duration requirements in accordance with IEEE C62.11-2005, Paragraph 8.12.

Procedures:

- Samples were preheated to 45°C.
- Each sample was impulsed with a 40kA crest current wave with a wave shape of 4x10 μ s.
- After one impulse, the sample was placed back into a 45°C oven and stabilized at that temperature.
- Each sample was impulsed a second time.
- Immediately following the second impulse, the sample was energized at K_C times MCOV ($K_C = 1$) for 30 minutes to show that there was no thermal recovery problem.
- The samples were inspected after testing to make sure that no physical damage occurred to make them operate differently.

Results:

The Cooper Power Systems Deadfront Arresters met the high-current, short duration requirements of two impulses, thermal recovery, and no physical damage.

SECTION J
T.O.V. TEMPORARY OVERVOLTAGE

Objective:

To verify what levels of 60 cycle temporary overvoltage the Cooper Power Systems Deadfront Arresters survive in accordance with IEEE C62.11-2005, Paragraph 8.15.

Procedures:

- Each VariGAP M.O.V.E. Arrester sample was measured for power-frequency sparkover.
- Each sample was impulsed with a 5kA crest, 8x20 μ s wave and the discharge voltage measured.
- Samples were preheated to 85°C.
- Each sample was removed from the oven and immediately placed onto the bushing and energized at the overvoltage.
- The overvoltage was removed before sample failure.
- Within 1 second, each sample was energized at MCOV for 30 minutes. Sample current and temperature were monitored for thermal runaway.
- Each sample was impulsed with a 5kA crest 8x20 μ s wave and the discharge voltage measured. The discharge voltage was compared to the discharge voltage taken prior to the Temporary Overvoltage testing to make sure that it did not vary by more than $\pm 10\%$.
- Each VariGAP M.O.V.E. Arrester sample was measured for power-frequency sparkover. The sparkover value was compared to the sparkover measured prior to Temporary Overvoltage testing to make sure that it did not vary by more than $\pm 10\%$.
- The samples were inspected after testing to assure that no physical damage occurred.
- Minimum recovery points were plotted.

Results:

Graph #1 and Chart 2 show the performance results for Deadfront M.O.V.E. arresters. Graph #2 and Chart 4 show the performance results for Deadfront VariGAP M.O.V.E. Arresters.

TEST K
DEADFRONT ARRESTER FAILURE MODE

Objective:

To verify that the Cooper Power Systems Deadfront Arresters are able to withstand valve block failures without ejecting arrester parts through the body of the housing, in accordance with IEEE C62.11-2005, Paragraph 8.20.

Procedures:

- 10kV rated 15kV Class M.O.V.E.'s were used for this test.
- Samples were electrically failed using a higher than rated voltage from a low-current source transformer at 60 Hz.
- The overvoltage was left on the samples until the short circuit current level of the source transformer was reached.
- The overvoltage was turned off, and within a few cycles, rated voltage was applied.
- Three samples were tested with an available fault current of 500 Amps for 0.3 seconds.
- Three samples were tested with an available fault current of 10,000 Amps for 0.17 seconds.

Results:

The Cooper Power Systems Deadfront Arrester samples withstood valve block failures without ejecting arrester parts through the body of the housing.

TEST L
CORONA VOLTAGE LEVEL TEST

Objective:

To verify that the Cooper Power Systems Deadfront Arresters meet corona extinction levels in accordance with IEEE 386-2006, Paragraph 7.4.

Procedures:

- Ten samples of each size and type of housing were tested.
- The test voltage was raised to 20% above the minimum corona voltage level.
- If the corona was less than 3 pC, the sample passed the tests.
- If the corona exceeded 3 pC, the test voltage was lowered to the minimum corona voltage.
- Corona readings were taken after 3 sec. and before 60 sec. The readings could not exceed 3 pC.

kV Class	Max. Voltage Rating (kV rms)	Min. Corona Voltage Level (kV rms)
15	8.3 / 14.4	11
25	15.2 / 26.3	19
35	21.1 / 36.6	26

Results:

The Cooper Power Systems Deadfront Arrester samples all passed the minimum corona requirements of IEEE 386-2006, Paragraph 7.4.

TEST M
IMPULSE WITHSTAND VOLTAGE TEST
(BIL)

Objective:

To demonstrate that the Cooper Power Systems Deadfront Arrester housings meet the impulse withstand voltage test in accordance with IEEE 386-2006, Paragraph 7.5.3.

Procedures:

- Ten samples of each size and type of housing were tested.
- The samples were subjected to 3 positive and 3 negative 1.2x50 μ s impulses. The crest values are listed below.
- The samples had to withstand all impulses without flashover or puncture.

kV Class	Max. Voltage Rating (kV rms)	Crest Voltage (kV)
15	8.3 / 14.4	95
25	15.2 / 26.3	125
35	21.1 / 36.6	150

Results:

The Cooper Power Systems Deadfront Arrester samples all passed the impulse requirements of IEEE 386-2006, Paragraph 7.5.3.

TEST N
A.C. WITHSTAND VOLTAGE TEST

Objective:

To verify that the Cooper Power Systems Deadfront Arrester housings meet the a.c. withstand voltage levels in accordance with IEEE 386-2006, Paragraph 7.5.1.

Procedures:

- Ten samples of each size and type of housing were tested.
- The test voltage was raised to the specified voltage withstand level listed below for one minute minimum.
- No flashover or puncture was allowed.

kV Class	Max. Voltage Rating (kV rms)	A.C. Withstand Level (kV)
15	8.3 / 14.4	34
25	15.2 / 26.3	40
35	21.1 / 36.6	50

Results:

The Cooper Power Systems Deadfront Arrester samples all passed the a.c. withstand test in accordance with IEEE 386-2006, Paragraph 7.5.1.

TEST 0
D.C. WITHSTAND VOLTAGE TEST

Objective:

To verify that the Cooper Power Systems Deadfront Arrester housings meet the d.c. withstand voltage level in accordance with IEEE 386-2006, Paragraph 7.5.2.

Procedures:

- Ten samples of each size and type of housing were tested.
- The test voltage was raised to the specified voltage withstand level listed below for 15 minutes minimum.
- No flashover or puncture was allowed.

kV Class	Max. Voltage Rating (kV rms)	D.C. Withstand Level (kV)
15	8.3 / 14.4	53
25	15.2 / 26.3	78
35	21.1 / 36.6	103

Results:

The Cooper Power Systems Deadfront Arrester samples all passed the dc withstand test in accordance with IEEE 386-2006, Paragraph 7.5.2.

TEST P
Operating Force Test

Objective:

To verify that the force necessary to operate a Cooper Power Systems Deadfront POSI-BREAK M.O.V.E. Arrester and Deadfront POSI-BREAK VariGAP Arrester meets the requirements of Paragraph 7.14 of IEEE-386-2006.

Procedures:

- Four samples of the POSI-BREAK M.O.V.E. Arrester were tested.
- The elbows were assembled with a probe and MOV block assembly. The connector system was lubricated in accordance with the manufacturer's instructions.
- The temperature of the components was set at -20°C , $+25^{\circ}\text{C}$ and $+65^{\circ}\text{C}$ respectively, for three separate tests.
- Each test consisted of closing the connector and the reopening it within 10 min.
- The force was applied to the operating eye parallel to the axis of the probe at a rate of 127mm/min (5 in/min).
- The required operating force over the environmental range of -20°C to $+65^{\circ}\text{C}$ shall be between 50-200 lbf.

Results:

The Cooper Power Systems Deadfront POSI-BREAK M.O.V.E. Arrester samples all passed the operating force test in accordance with IEEE 386-2006, Paragraph 7.14. Each set of four connector/bushing insert assemblies had operating forces between 50 lbf and 200 lbf at -20°C , $+25^{\circ}\text{C}$ and $+65^{\circ}\text{C}$.

TEST Q

Operating Interface AC Withstand Test – Annex B, Option B

Objective:

To demonstrate that the Cooper Power Systems Deadfront POSI-BREAK M.O.V.E. Arrester and Deadfront POSI-BREAK VariGAP Arrester are capable of performing an opening operation under high operating force, low temperature, elevated voltage and zero load current conditions without a flashover to ground.

Procedures:

- Insulative plugs were assembled into 16 POSI-BREAK M.O.V.E. arrester housings in place of the arrester blocks.
- The 16 samples were then installed onto 25kV bushing inserts with beveled latch ring – Cooper Power Systems catalog # LBI225 (p/n 2690557D53 rev. 70). The 200 Amp operating interface was lubricated according to the manufacturer's instructions with the complete contents of the packet of silicone grease supplied with the M.O.V.E. arrester.
- All 16 connector assemblies were heat aged at $120 \pm 5^{\circ}\text{C}$ for a total of 3 weeks.
- After the full 3 weeks in the oven at $120 \pm 5^{\circ}\text{C}$, all the connector assemblies were removed and allowed to cool to ambient. The test samples were then placed in a cold chamber at -20 to -25°C for a minimum of 16 hours.
- For 12 of the 16 test samples, one sample was removed at a time from the cold chamber and mounted to the faceplate of a grounded test stand. Adjacent grounds were not required. The face plate mounting was equipped with threaded mounting studs and a bushing well clamp located in a manner duplicating a typical field application. The separable connector, POSI-BREAK M.O.V.E. Arrester, was separated from the bushing within 5 minutes after removal from the cold chamber. The opening operation was performed with a positive continuous motion applied by a mechanical actuator at 35-in/sec average speed over the initial 1 inch of travel. The force was applied to the operating eye of the connector using suitable live-line tool or equivalent.
- The test circuit and circuit parameters are detailed in the following Figure A and Table A. The line-to-ground test voltage for the 15.2/26.3kV rated connectors was 30.5kV rms. (2x Rated L-G voltage.)
- The opening force of the four remaining samples was measured. A force was applied to the operating eye parallel to the axis of the probe at a rate of 5-in/min.

FIGURE A
Circuit Diagram

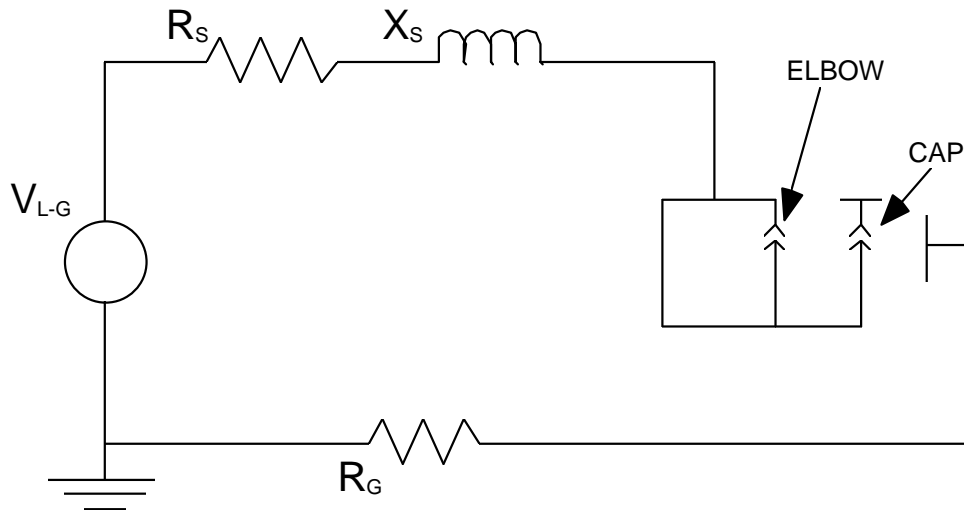

TABLE A
Circuit Parameters

$$V_{LG} = 2 \times (\text{RATED L-G Voltage})$$

$$Z_S = X_S + R_S$$

$$X_S/R_S = 5.0 - 7.0$$

$$Z_S \geq 0.10 \times R_G$$

$$I_F = V/(Z_S + R_G) \geq 50 \text{ Amps}$$

Results:

Twelve consecutive Deadfront POSI-BREAK M.O.V.E. Arresters were successfully switched when mated with a Cooper 25kV bushing insert with beveled latch ring without flashover to ground at 30.5kV line-to-ground test voltage in accordance with Annex B, Option B of IEEE 386-2006. The opening force measured ranged from 165 – 258 lbf.

TEST R
CORONA VOLTAGE LEVEL TEST
25kV – POSI-BREAK Interface

Objective:

To verify that the Cooper Power Systems Deadfront POSI-BREAK M.O.V.E. Arrester AND Deadfront POSI-BREAK VariGAP M.O.V.E. Arrester meet corona extinction levels in accordance with IEEE 386-2006, Paragraph 7.4.

Procedures:

- Ten samples of the POSI-BREAK M.O.V.E. Arrester housing were tested.
- The test voltage was raised to 20% above the minimum corona voltage level.
- If the corona was less than 3 pC, the sample passed the tests.
- If the corona exceeded 3 pC, the test voltage was lowered to the minimum corona voltage.
- Corona readings were taken after 3 sec. and before 60 sec. The readings could not exceed 3 pC.

kV Class	Max. Voltage Rating (kV rms)	Min. Corona Voltage Level (kV rms)
25	15.2 / 26.3	19

Results:

The Cooper Power Systems Deadfront POSI-BREAK M.O.V.E. Arrester samples all passed the minimum corona requirements of IEEE 386-2006, Paragraph 7.4.

TEST S
IMPULSE WITHSTAND VOLTAGE TEST
(BIL)
25kV – POSI-BREAK Interface

Objective:

To demonstrate that the Cooper Power Systems Deadfront POSI-BREAK M.O.V.E. Arrester and Deadfront POSI-BREAK VariGAP M.O.V.E. Arrester housings meet the impulse withstand voltage test in accordance with IEEE 386-2006, Paragraph 7.5.3.

Procedures:

- Ten samples of the POSI-BREAK M.O.V.E. Arrester housing were tested.
- The samples were subjected to 3 positive and 3 negative 1.2x50 μ s impulses. The crest values are listed below.
- The samples had to withstand all impulses without flashover or puncture.

kV Class	Max. Voltage Rating (kV rms)	Crest Voltage (kV)
25	15.2 / 26.3	125

Results

The Cooper Power Systems Deadfront POSI-BREAK M.O.V.E. Arrester samples all passed the impulse requirements of IEEE 386-2006, Paragraph 7.5.3.

TEST I
A.C. WITHSTAND VOLTAGE TEST
25kV – POSI-BREAK Interface

Objective:

To verify that the Cooper Power Systems Deadfront POSI-BREAK M.O.V.E. Arrester and Deadfront POSI-BREAK VariGAP M.O.V.E. Arrester housings meet the A.C. withstand voltage levels in accordance with IEEE 386-2006, Paragraph 7.5.1.

Procedures:

- Ten samples of THE POSI-BREAK M.O.V.E. Arrester housing were tested.
- The test voltage was raised to the specified voltage withstand level listed below for one minute minimum.
- No flashover or puncture was allowed.

kV Class	Max. Voltage Rating (kV rms)	A.C. Withstand Level (kV)
25	15.2 / 26.3	40

Results:

The Cooper Power Systems Deadfront POSI-BREAK M.O.V.E. Arrester samples all passed the A.C. withstand test in accordance with IEEE 386-2006, Paragraph 7.5.1.

TEST U
D.C. WITHSTAND VOLTAGE TEST
25kV – POSI-BREAK Interface

Objective:

To verify that the Cooper Power Systems Deadfront POSI-BREAK M.O.V.E. Arrester and Deadfront POSI-BREAK VariGAP M.O.V.E. Arrester housings meet the D.C. withstand voltage level in accordance with IEEE 386-2006, Paragraph 7.5.2.

Procedures:

- Ten samples of the POSI-BREAK M.O.V.E. Arrester housing were tested.
- The test voltage was raised to the specified voltage withstand level listed below for 15 minutes minimum.
- No flashover or puncture was allowed.

kV Class	Max. Voltage Rating (kV rms)	D.C. Withstand Level (kV)
25	15.2 / 26.3	78

Results:

The Cooper Power Systems Deadfront POSI-BREAK M.O.V.E. Arrester samples all passed the D.C. withstand test in accordance with IEEE 386-2006, Paragraph 7.5.2.

CHART 1

M.O.V.E. ARRESTERS

DUTY CYCLE VOLTAGE RATING (kV)	MCOV kV	EQUIVALENT FRONT-OF-WAVE (kV)	MAXIMUM DISCHARGE VOLTAGE (kV CREST) 8/20 μ s Current Wave)					
			0.5kA	1.5kA	3kA	5kA	10kA	20kA
3	2.55	13.7	10.0	10.7	12.0	12.8	13.4	15.7
6	5.1	27.4	20.0	21.9	24.5	26.2	28.6	34.9
9	7.65	37.4	25.7	27.4	29.9	31.4	34.7	38.4
10	8.4	39.7	27.3	28.4	30.6	32.9	36.7	40.4
12	10.2	56.1	38.5	41.1	44.8	47.1	52.0	57.6
15	12.7	63.0	42.0	45.0	49.2	52.5	57.8	66.0
18	15.3	74.8	51.3	54.7	59.7	62.7	69.3	76.8
21	17.0	81.7	54.9	58.7	64.2	68.2	75.2	85.2
24	19.5	95.8	65.3	69.7	76.1	80.2	88.6	98.8
27	22.0	105.0	70.0	75.0	82.0	87.4	96.2	110.0
30	24.4	112.0	74.2	79.5	85.7	91.8	100.0	115.0

CHART 2

**TOV RECOVERY CAPABILITY OF
 M.O.V.E. ARRESTERS AT 85°C**

time, s	per unit of MCOV
0.02	2.090
0.1	1.653
1	1.568
10	1.492
100	1.425
1000	1.368
10000	1.292

CHART 3

VariGAP M.O.V.E. ARRESTERS

ARRESTER RATING kV RMS	MCOV kV RMS	FRONT-OF-WAVE PROTECTIVE LEVEL* kV CREST	MIN. 60 Hz SPARKOVER kV CREST $1/\sqrt{2}$	MAXIMUM DISCHARGE VOLTAGE (kV CREST) 8/20 μ s Current Wave					
				0.5kA	1.5kA	3kA	5kA	10kA	20kA
9	7.65	25.8/28.5	13.5	19.5	21.2	23.8	24.7	28.5	33.3
10	8.4	27.1/30.0	15.0	20.5	22.3	25.0	26.0	30.0	35.0
12	10.2	35.5/39.5	18.0	25.0	27.0	29.6	31.4	36.8	43.2
15	12.7	37.8/41.0	22.5	30.0	31.3	33.7	36.2	40.4	44.5
18	15.3	48.8/59.3	27.0	35.8	40.2	44.4	46.8	49.4	60.5
21	17.0	60.1/65.3	31.5	39.4	44.3	48.9	51.5	54.4	66.6
24	19.5	64.4/70.0	36.0	44.1	47.3	51.7	55.2	60.7	69.4
27	22.0	70.9/79.0	40.5	49.8	54.0	57.9	62.8	73.4	86.2

* Num 1/Num 2

Num 1 – This is the value of the sparkover of the gap assembly based on a wave rising 100kV per μ s per 12kV of arrester rating.

Num 2 – Based on 5kA current impulse that results in a discharge voltage cresting in 0.5 μ s, this is the equivalent front-of-wave.

CHART 4

**TOV RECOVERY CAPABILITY OF
 VariGAP MOVE ARRESTERS AT 85°C**

time, s	per unit of MCOV
0.02	1.830
0.1	1.830
1	1.828
10	1.825
100	1.822
1000	1.820

CHART 5

VariGAP M.O.V.E. 1.2/50 SPARKOVER

DUTY CYCLE RATING kV RMS	MAX 1.2/50 SPARKOVER KV CREST
9	24.2
10	25.5
12	31.3
15	36.0
18	42.8
21	51.3
24	55.0
27	62.5

GRAPH 1

TOV Recovery Curve of M.O.V.E. Arresters at 85°C

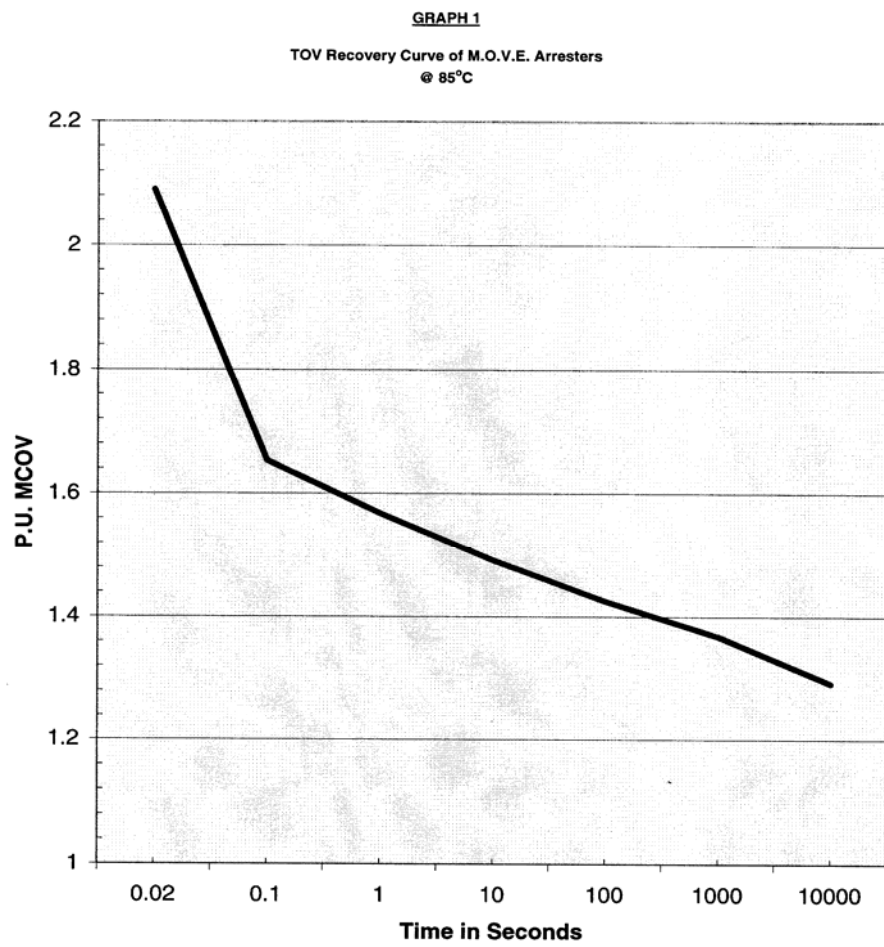

GRAPH 2

TOV Recovery Curve of VariGAP
M.O.V.E. Arresters at 85°C

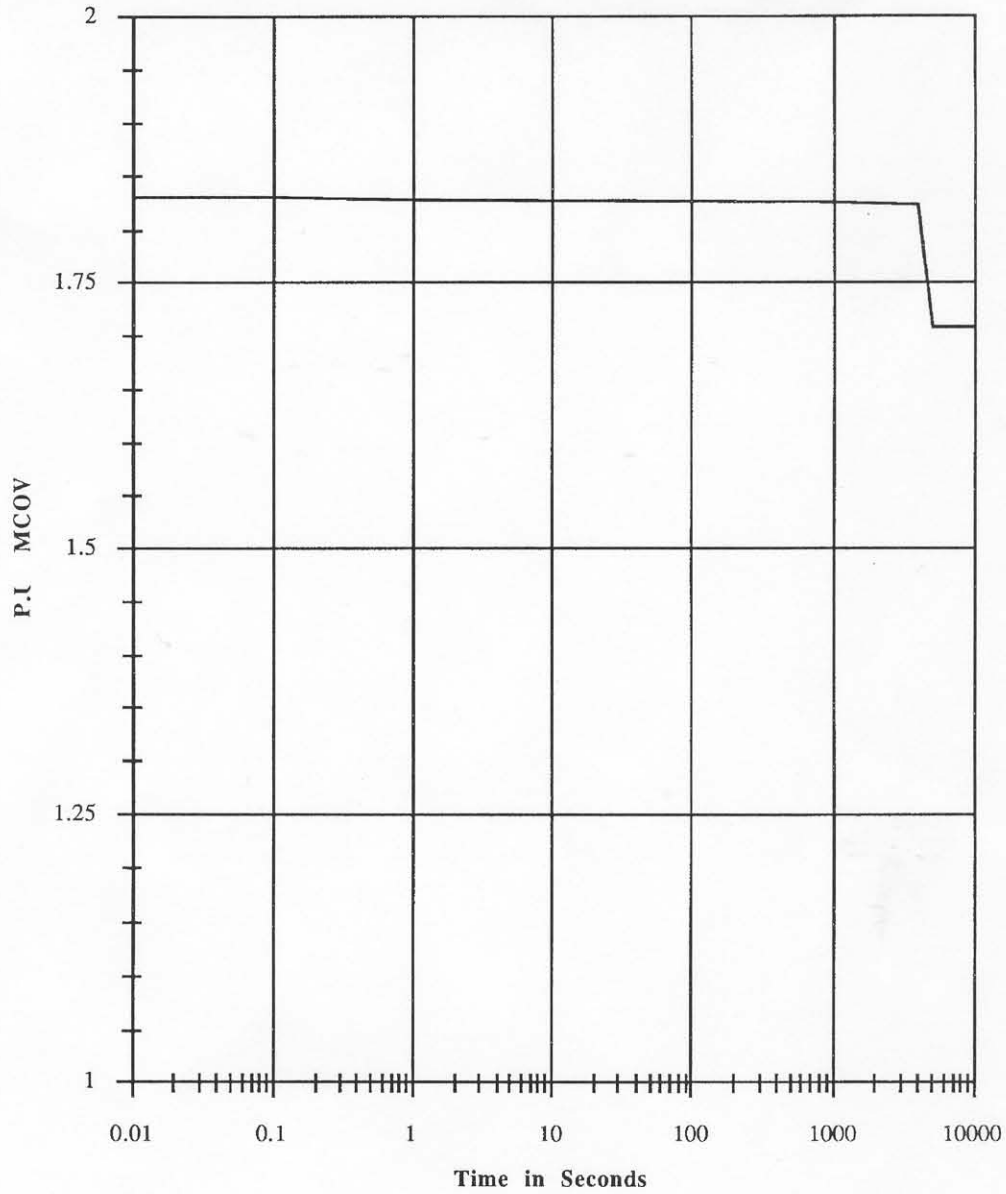

COOPER Power Systems

Quality from
Cooper Industries

P.O. Box 1640, Waukesha, WI 53187

VariGAP® is a registered trademark of Cooper Industries, Inc.

REVISION TABLE

REVISION NO.	DATE	WHAT WAS ADDED/CHANGED
3	9/21/04	Update standard references throughout report
4	3/01/07	Update graph 1
5	3/20/07	Modify Chart 2
6	3/23/07	Modify report reference new standards
7	11/6/07	Add Test Results of POSIBREAK M.O.V.E